

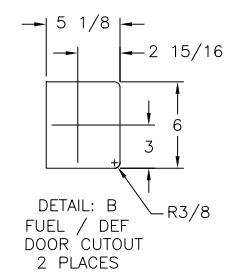

| REVISIONS |        |                 |          |     |     |
|-----------|--------|-----------------|----------|-----|-----|
| CHK DATE  | CHK BY | DESCRIPTION     | DATE     | BY  | REV |
| 12/01/22  | PJS    | INITIAL RELEASE | 12/01/22 | JRP | 00  |

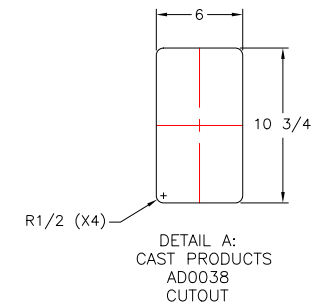
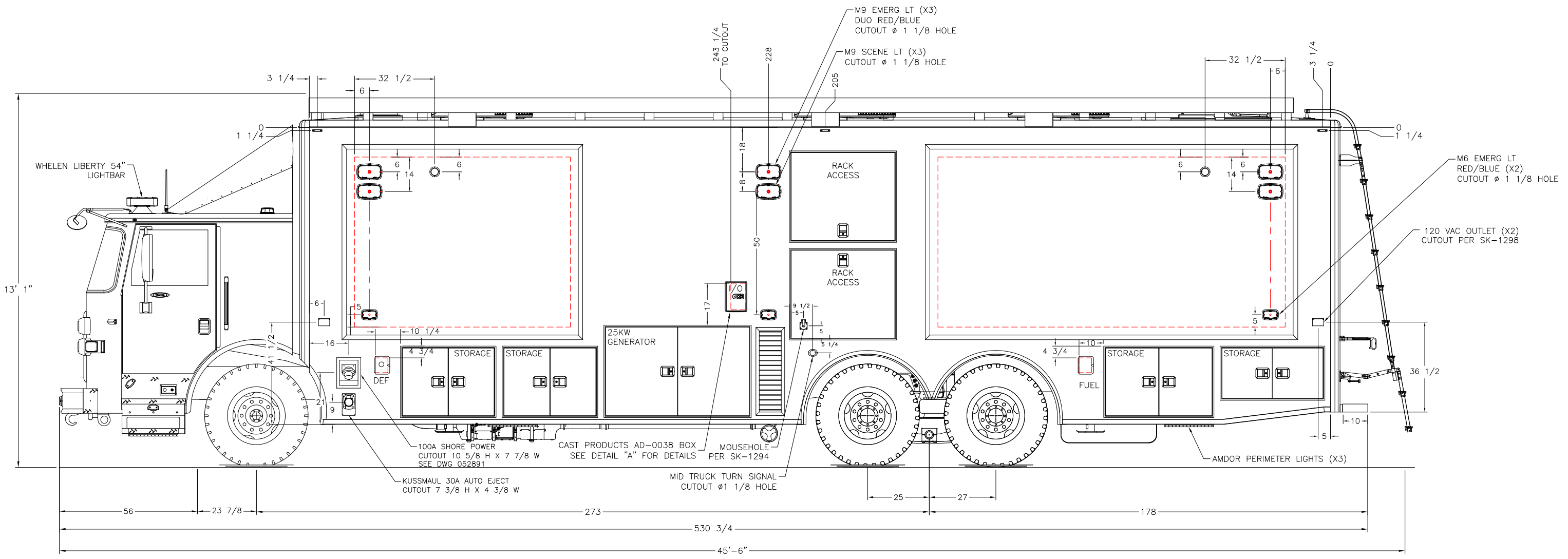

THIS DRAWING IS THE PROPERTY OF FRONTLINE COMMUNICATIONS CORPORATION. IT IS CONFIDENTIAL AND ALL RIGHTS ARE RESERVED. IT SHALL NOT BE REPRODUCED, COPIED, LENT, NOR USED FOR ANY PURPOSE OTHER THAN THAT FOR WHICH IT IS SPECIFICALLY FURNISHED.

|   |                                 |   |                               |
|---|---------------------------------|---|-------------------------------|
| DO NOT SCALE THIS DRAWING<br>DIMENSIONS ARE IN INCHES<br>UNLESS OTHERWISE SPECIFIED                             | MATERIAL<br><b>SEE CALLOUTS</b> | <p>12770 44th Street North<br/>Clearwater, FL. 33762-4713<br/>(727) 573-0400<br/>FAX (727) 571-3295</p> |                               |
| TOLERANCES:<br>ANGULAR: ± 1° BEND: ± 1°<br>2 PLACE DECIMAL ± .010<br>3 PLACE DECIMAL ± .005<br>FRACTIONS ± 1/16 | FINISH<br><b>SEE W/O</b>        | <p><b>EXTERIOR LAYOUT STREET SIDE</b></p>   |                               |
| JOB NUMBER OR PRODUCT LINE<br><b>91975</b>  | DRAWN BY<br><b>JRP</b>          | DATE<br><b>12/01/22</b>   | SIZE<br><b>B</b>              |
| SHEET<br><b>1 OF 1</b>  | SCALE<br><b>1:40</b>            | CHECKED BY<br><b>PJS</b>  | DWG NO.<br><b>91975-50300</b> |

| REVISIONS |        |                 |  |  |          |     |     |
|-----------|--------|-----------------|--|--|----------|-----|-----|
| CHK DATE  | CHK BY | DESCRIPTION     |  |  | DATE     | BY  | REV |
| 12/01/22  | PJS    | INITIAL RELEASE |  |  | 12/01/22 | JRP | 00  |

PERIMETER CAMERA

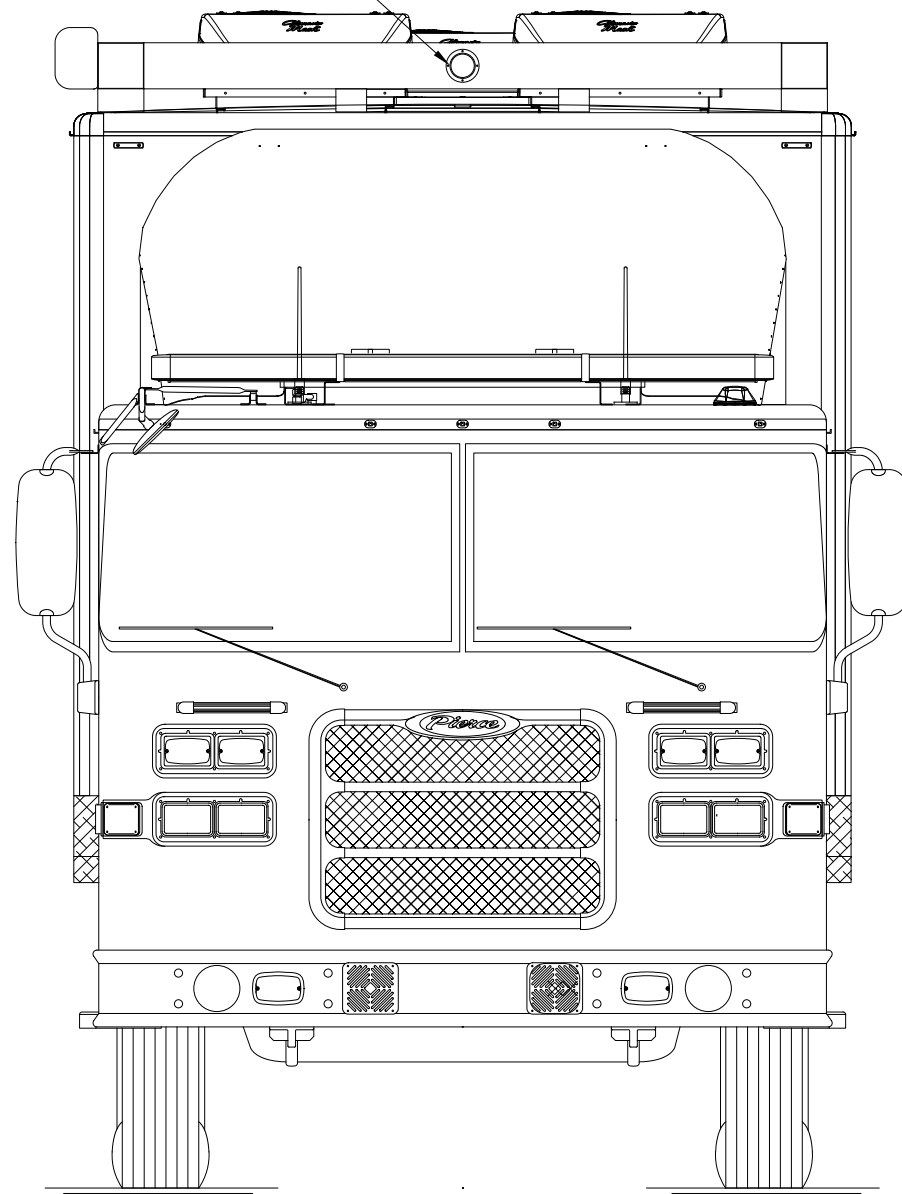

MARKER LIGHTS

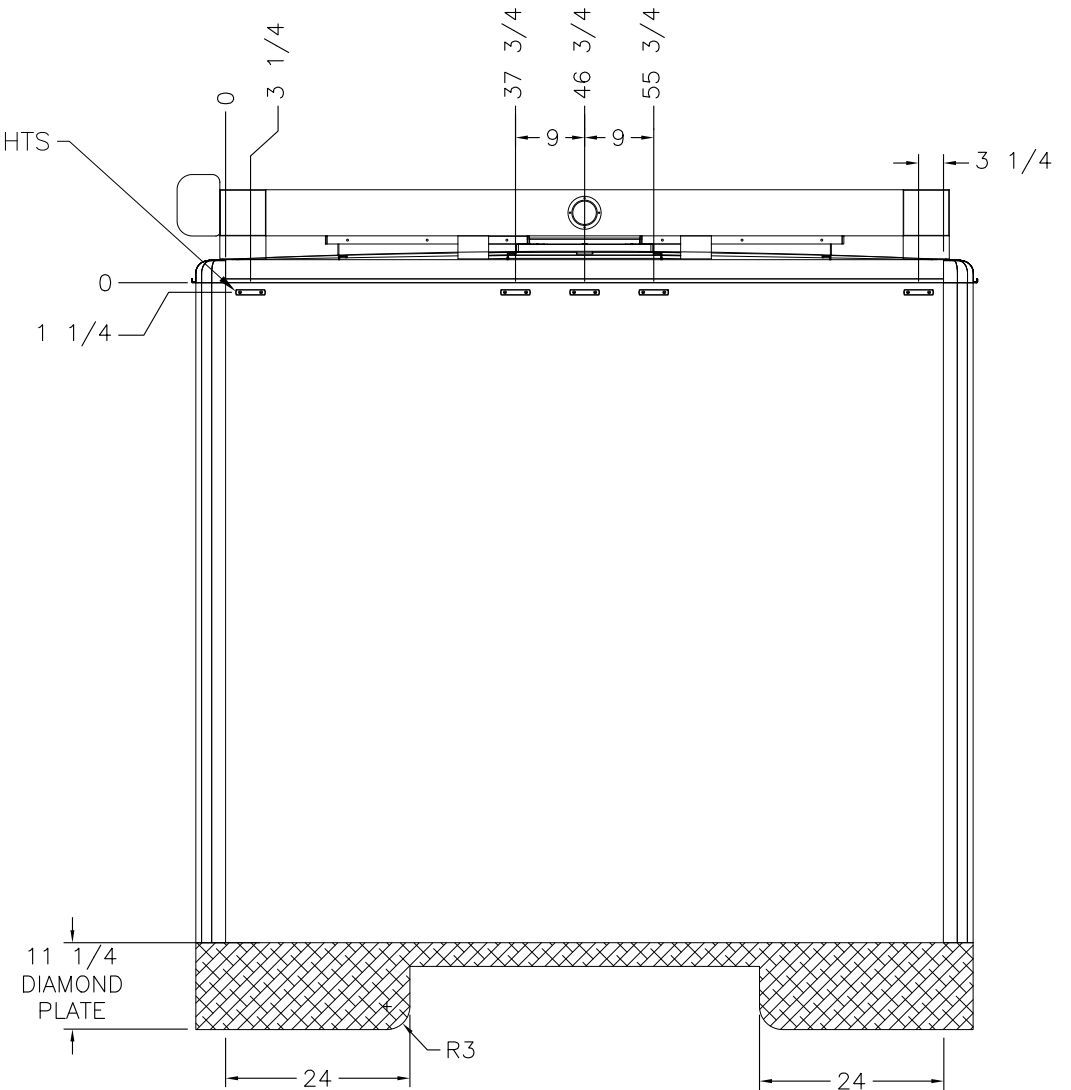

DO NOT SCALE THIS DRAWING  
DIMENSIONS ARE IN INCHES  
UNLESS OTHERWISE SPECIFIED

TOLERANCES:  
ANGULAR: ± 1° BEND: ± 1°  
2 PLACE DECIMAL ± .010  
3 PLACE DECIMAL ± .005  
FRACTIONS ± 1/16

MATERIAL  
**SEE CALLOUTS**

FINISH  
**SEE W/O**

**FRONTLINE COMMUNICATIONS**  
A Division of Pierce Manufacturing Inc.

12770 44th Street North  
Clearwater, FL. 33762-4713  
(727) 573-0400  
FAX (727) 571-3295

**EXTERIOR LAYOUT FRONT**

THIS DRAWING IS THE PROPERTY OF FRONTLINE COMMUNICATIONS CORPORATION. IT IS CONFIDENTIAL AND ALL RIGHTS ARE RESERVED. IT SHALL NOT BE REPRODUCED, COPIED, LENT, NOR USED FOR ANY PURPOSE OTHER THAN THAT FOR WHICH IT IS SPECIFICALLY FURNISHED.

JOB NUMBER OR PRODUCT LINE  
**91975**

SHEET **1 OF 1** SCALE **1:25**

DRAWN BY **JRP** DATE **12/01/22**

CHECKED BY **PJS** DATE **12/01/22**

SIZE **B** DWG NO. **91975-50400**

| REVISIONS |        |                                  |          |     |     |
|-----------|--------|----------------------------------|----------|-----|-----|
| CHK DATE  | CHK BY | DESCRIPTION                      | DATE     | BY  | REV |
| 01/10/23  | PJS    | RELOCATED LIGHTS TO CLEAR LADDER | 01/10/23 | JRP | 01  |

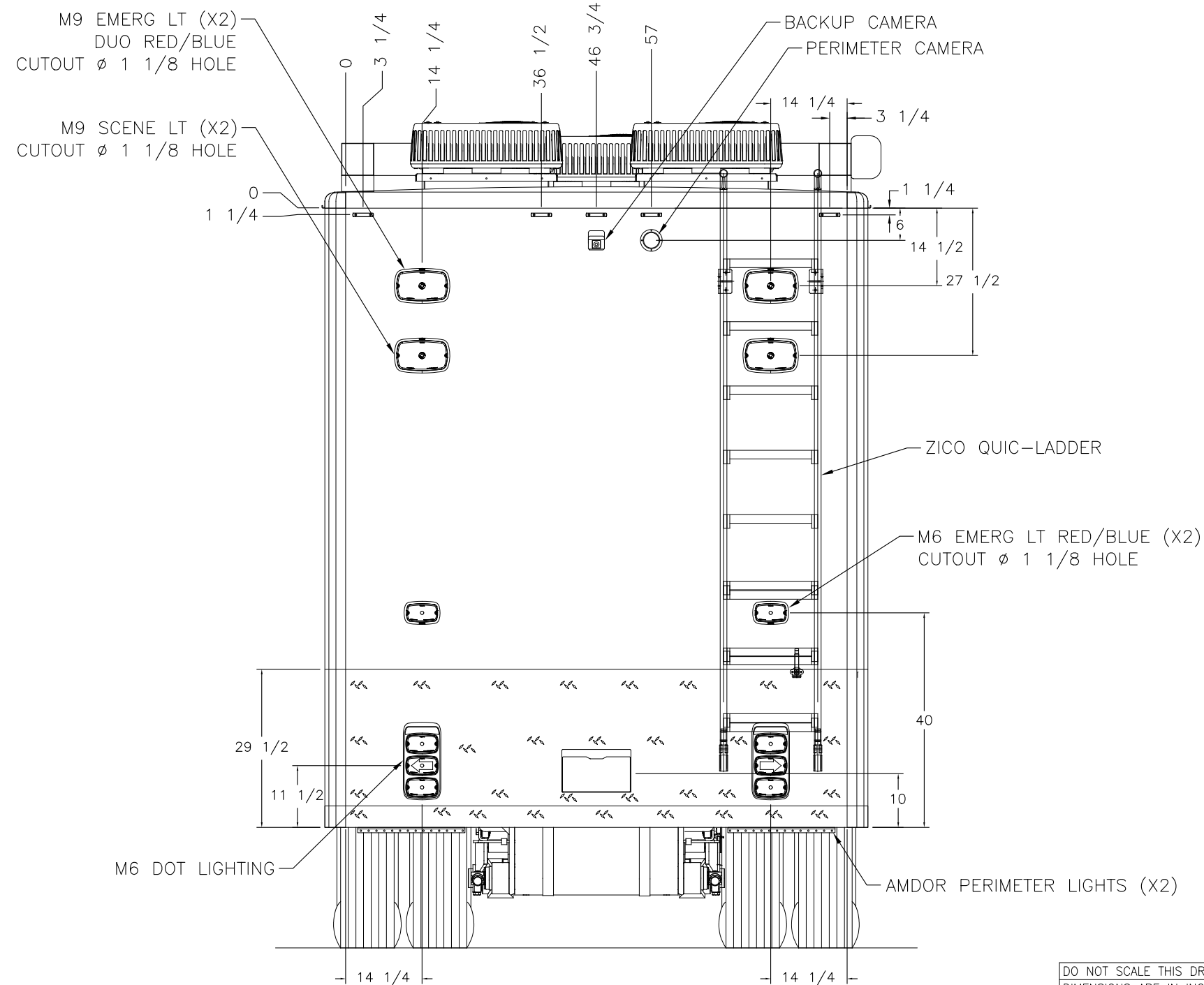

DO NOT SCALE THIS DRAWING  
 DIMENSIONS ARE IN INCHES  
 UNLESS OTHERWISE SPECIFIED

TOLERANCES:  
 ANGULAR: ± 1° BEND: ± 1°  
 2 PLACE DECIMAL ± .010  
 3 PLACE DECIMAL ± .005  
 FRACTIONS ± 1/16

MATERIAL  
**SEE CALLOUTS**

FINISH  
**SEE W/O**

**FRONTLINE COMMUNICATIONS**  
 A Division of Pierce Manufacturing Inc.

12770 44th Street North  
 Clearwater, FL. 33762-4713  
 (727) 573-0400  
 FAX (727) 571-3295

**EXTERIOR LAYOUT REAR**

THIS DRAWING IS THE PROPERTY OF FRONTLINE COMMUNICATIONS CORPORATION. IT IS CONFIDENTIAL AND ALL RIGHTS ARE RESERVED. IT SHALL NOT BE REPRODUCED, COPIED, LENT, NOR USED FOR ANY PURPOSE OTHER THAN THAT FOR WHICH IT IS SPECIFICALLY FURNISHED.

JOB NUMBER OR PRODUCT LINE  
**91975**

SHEET  
**1 OF 1**

SCALE  
**1:25**

DRAWN BY  
**JRP**

CHECKED BY  
**PJS**

DATE  
**12/01/22**

DATE  
**12/01/22**

SIZE  
**B**

DWG NO.  
**91975-50500**

| REVISIONS |        |   |          |     |     |
|-----------|--------|---|----------|-----|-----|
| CHK DATE  | CHK BY | DESCRIPTION                             | DATE     | BY  | REV |
| 10/30/23  | CJM    | NUMBER OF "REMOVABLE TABLE LEGS" WAS 2. | 10/30/23 | MSS | 02  |

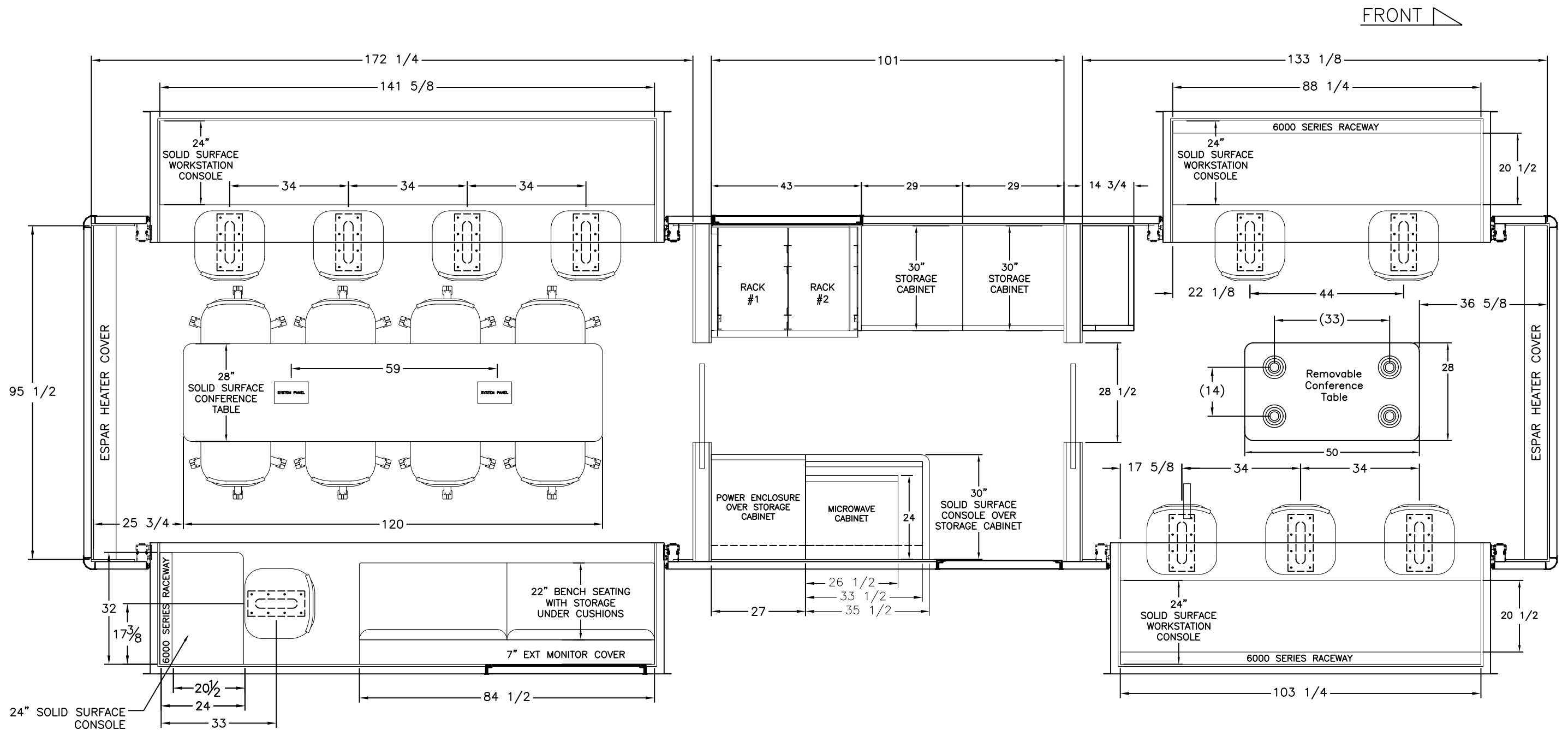

|   |        |            |     |   |             |
|---|--------|------------|-----|---|-------------|
| DO NOT SCALE THIS DRAWING<br>DIMENSIONS ARE IN INCHES<br>UNLESS OTHERWISE SPECIFIED                             |        | MATERIAL   | N/A | <b>FRONTLINE COMMUNICATIONS</b><br><small>A Division of Pierce Manufacturing Inc.</small><br>12770 44th Street North<br>Clearwater, FL 33762-4713<br>(727) 573-0400<br>FAX (727) 571-3295 |             |
| TOLERANCES:<br>ANGULAR: ± 1° BEND: ± 1°<br>2 PLACE DECIMAL ± .010<br>3 PLACE DECIMAL ± .005<br>FRACTIONS ± 1/16 |        | FINISH     | N/A |   |             |
| JOB NUMBER OR PRODUCT LINE  | 91975  | DRAWN BY   | JRP | DATE  | 12/01/22    |
| SHEET   | 1 OF 1 | CHECKED BY | PJS | DATE  | 12/01/22    |
| SCALE   | 1:30   | SIZE       | B   | DWG NO.   | 91975-40100 |

THIS DRAWING IS THE PROPERTY OF FRONTLINE COMMUNICATIONS CORPORATION. IT IS CONFIDENTIAL AND ALL RIGHTS ARE RESERVED. IT SHALL NOT BE REPRODUCED, COPIED, LENT, NOR USED FOR ANY PURPOSE OTHER THAN THAT FOR WHICH IT IS SPECIFICALLY FURNISHED.

FRONT ↗

| REVISIONS |        |                 |          |     |     |
|-----------|--------|-----------------|----------|-----|-----|
| CHK DATE  | CHK BY | DESCRIPTION     | DATE     | BY  | REV |
| 12/01/22  | PJS    | INITIAL RELEASE | 12/01/22 | JRP | 00  |

FRONT

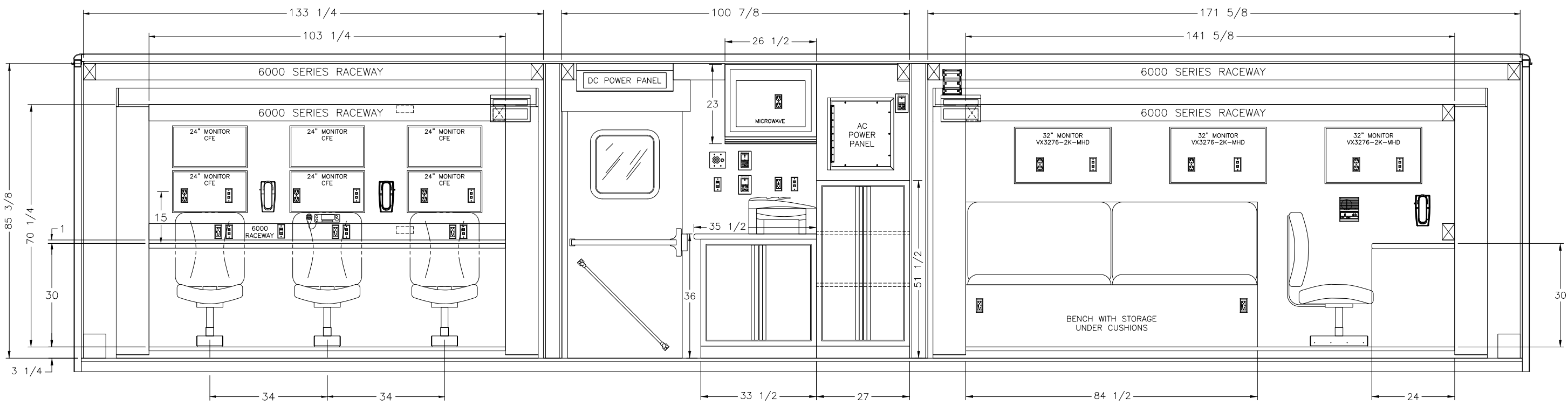

- RADIO HEAD
- PHONE
- DOOR ENTRY CONTROL
- INTERCOM
- A/C THERMOSTAT
- 120V AC POWER GFCI
- 120V AC POWER POINT (DUPLICATE W/ USB A & C)
- 120 VAC POWER POINT
- LIGHTING CONTROL
- LOW VOLTAGE DEVICE RING (SYSTEMS WIRING)





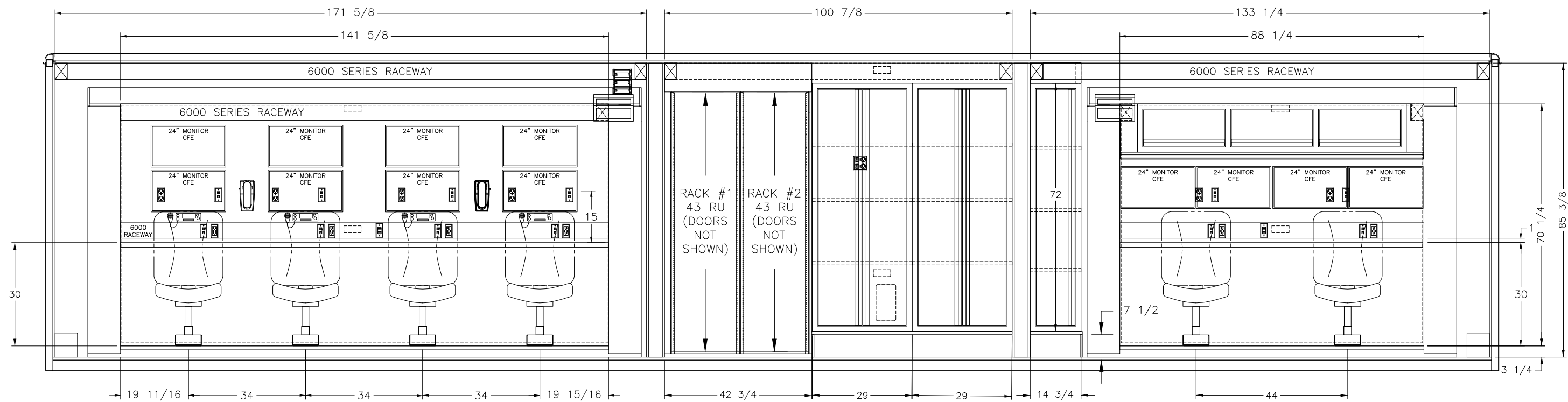

|   |                      |                                 |                         |   |  |
|---|----------------------|---------------------------------|-------------------------|---|--|
| DO NOT SCALE THIS DRAWING<br>DIMENSIONS ARE IN INCHES<br>UNLESS OTHERWISE SPECIFIED                             |                      | MATERIAL<br><b>SEE CALLOUTS</b> |                         | <br>12770 44th Street North<br>Clearwater, FL. 33762-4713<br>(727) 573-0400<br>FAX (727) 571-3295 |  |
| TOLERANCES:<br>ANGULAR: ± 1° BEND: ± 1°<br>2 PLACE DECIMAL ± .010<br>3 PLACE DECIMAL ± .005<br>FRACTIONS ± 1/16 |                      | FINISH<br><b>SEE W/O</b>        |                         |   |  |
| JOB NUMBER OR PRODUCT LINE<br><b>91975</b>  |                      | DRAWN BY<br><b>JRP</b>          | DATE<br><b>12/01/22</b> | <b>INTERIOR LAYOUT CURB SIDE</b>  |  |
| SHEET<br><b>1 OF 1</b>  | SCALE<br><b>1:30</b> | CHECKED BY<br><b>PJS</b>        | DATE<br><b>12/01/22</b> |   |  |

THIS DRAWING IS THE PROPERTY OF FRONTLINE COMMUNICATIONS CORPORATION. IT IS CONFIDENTIAL AND ALL RIGHTS ARE RESERVED. IT SHALL NOT BE REPRODUCED, COPIED, LENT, NOR USED FOR ANY PURPOSE OTHER THAN THAT FOR WHICH IT IS SPECIFICALLY FURNISHED.

| REVISIONS |        |                 |          |     |     |
|-----------|--------|-----------------|----------|-----|-----|
| CHK DATE  | CHK BY | DESCRIPTION     | DATE     | BY  | REV |
| 12/01/22  | PJS    | INITIAL RELEASE | 12/01/22 | JRP | 00  |

FRONT 



-  - RADIO HEAD
-  - PHONE
-  - 120 VAC POWER FOR RADIOS
-  - 120 VAC POWER POINT
-  - 120V AC POWER POINT (DUPLEX W/ USB A & C)
-  - LIGHTING CONTROL
-  - LOW VOLTAGE DEVICE RING (SYSTEMS WIRING)

THIS DRAWING IS THE PROPERTY OF FRONTLINE COMMUNICATIONS CORPORATION. IT IS CONFIDENTIAL AND ALL RIGHTS ARE RESERVED. IT SHALL NOT BE REPRODUCED, COPIED, LENT, NOR USED FOR ANY PURPOSE OTHER THAN THAT FOR WHICH IT IS SPECIFICALLY FURNISHED.

|   |                      |                                 |                         |  |                               |
|---|----------------------|---------------------------------|-------------------------|--|-------------------------------|
| DO NOT SCALE THIS DRAWING<br>DIMENSIONS ARE IN INCHES<br>UNLESS OTHERWISE SPECIFIED                             |                      | MATERIAL<br><b>SEE CALLOUTS</b> |                         | <br>12770 44th Street North<br>Clearwater, FL. 33762-4713<br>(727) 573-0400<br>FAX (727) 571-3295 |                               |
| TOLERANCES:<br>ANGULAR: ± 1° BEND: ± 1°<br>2 PLACE DECIMAL ± .010<br>3 PLACE DECIMAL ± .005<br>FRACTIONS ± 1/16 |                      | FINISH<br><b>SEE W/O</b>        |                         | <b>INTERIOR LAYOUT<br/>STREET SIDE</b>   |                               |
| JOB NUMBER OR PRODUCT LINE<br><b>91975</b>  |                      | DRAWN BY<br><b>JRP</b>          | DATE<br><b>12/01/22</b> |  |                               |
| SHEET<br><b>1 OF 1</b>  | SCALE<br><b>1:30</b> | CHECKED BY<br><b>PJS</b>        | DATE<br><b>12/01/22</b> | SIZE<br><b>B</b>   | DWG NO.<br><b>91975-40300</b> |

| REVISIONS |        |                 |          |     |     |
|-----------|--------|-----------------|----------|-----|-----|
| CHK DATE  | CHK BY | DESCRIPTION     | DATE     | BY  | REV |
| 12/01/22  | PJS    | INITIAL RELEASE | 12/01/22 | JRP | 00  |

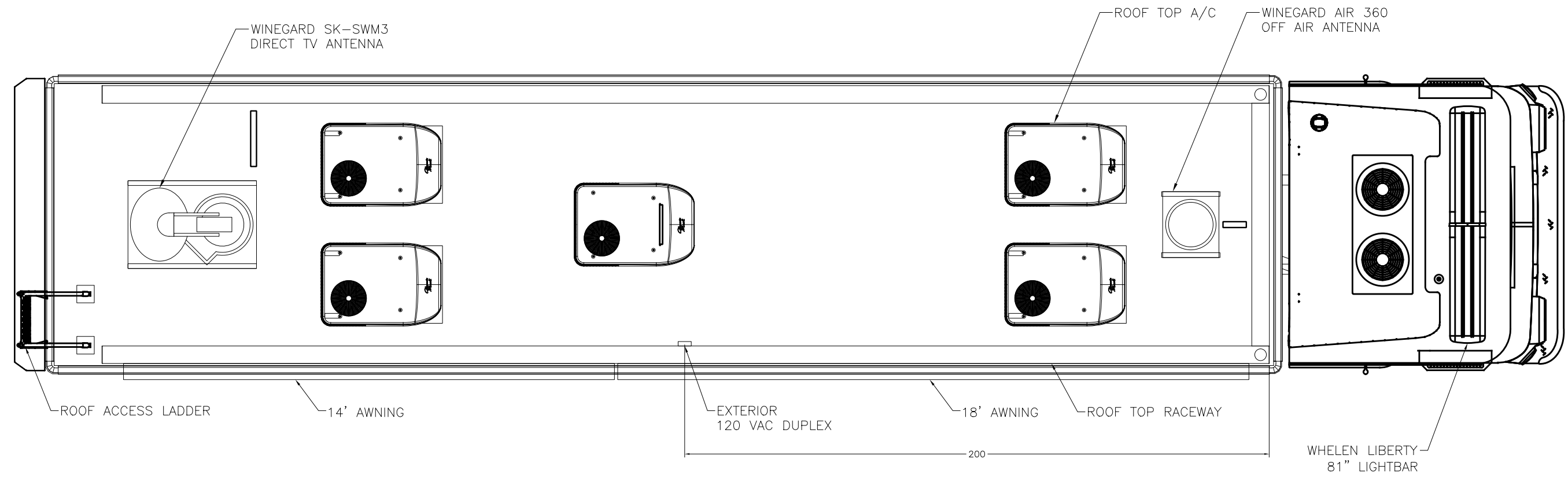

DO NOT SCALE THIS DRAWING  
 DIMENSIONS ARE IN INCHES  
 UNLESS OTHERWISE SPECIFIED

TOLERANCES:  
 ANGULAR: ± 1° BEND: ± 1'  
 2 PLACE DECIMAL ± .010  
 3 PLACE DECIMAL ± .005  
 FRACTIONS ± 1/16

MATERIAL  
**SEE CALLOUTS**

FINISH  
**SEE W/O**

**FRONTLINE COMMUNICATIONS**  
 A Division of Pierce Manufacturing Inc.

12770 44th Street North  
 Clearwater, FL. 33762-4713  
 (727) 573-0400  
 FAX (727) 571-3295

THIS DRAWING IS THE PROPERTY OF FRONTLINE COMMUNICATIONS CORPORATION. IT IS CONFIDENTIAL AND ALL RIGHTS ARE RESERVED. IT SHALL NOT BE REPRODUCED, COPIED, LENT, NOR USED FOR ANY PURPOSE OTHER THAN THAT FOR WHICH IT IS SPECIFICALLY FURNISHED.

JOB NUMBER OR PRODUCT LINE  
**91975**

DRAWN BY  
**JRP**

DATE  
**12/01/22**

CHECKED BY  
**PJS**

DATE  
**12/01/22**

**EXTERIOR LAYOUT ROOF**

SIZE **B** DWG NO. **91975-50600**