

**FRONTLINE**  
COMMUNICATIONS  
A Division of Pierce Manufacturing Inc.

San Ramon Valley  
Fire Department  
C-45 X-4 - M2-112

THIS DRAWING IS THE PROPERTY OF PIERCE MANUFACTURING. IT IS CONFIDENTIAL AND ALL RIGHTS ARE RESERVED. IT SHALL NOT BE REPRODUCED, COPIED, LENT, OR USED FOR ANY PURPOSE OTHER THAN THAT FOR WHICH IT IS SPECIFICALLY FURNISHED.

BID # XXXXX  
REP: Rich Myers - Golden State Fire Apparatus  
DEALER: Andy Callaway - Frontline Communications

PRELIMINARY USE ONLY  
THIS DRAWING IS FOR REPRESENTATION ONLY. DETAILED ENGINEERING DRAWINGS WILL BE CREATED FOR MANUFACTURING. CHANGES MAY BE REQUIRED TO ACCOMMODATE MANUFACTURING REQUIREMENTS AND CUSTOMER SPECIFICATIONS.

|       |        |              |        |
|-------|--------|--------------|--------|
| DRAWN | MRS    | DATE         | 1/6/22 |
| SHEET | 1 OF 6 | NOT TO SCALE |        |

|      |          |     |
|------|----------|-----|
| SIZE | DWG NO.  | REV |
| B    | P2022-36 | A   |

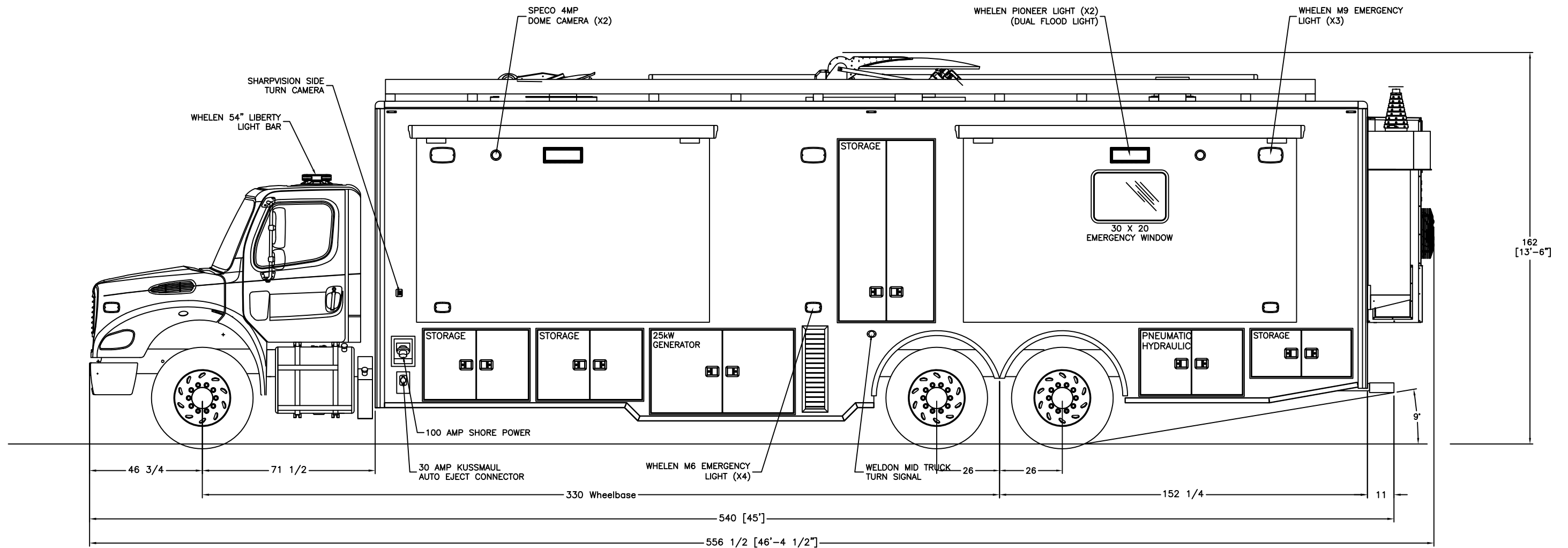

**FRONTLINE**  
COMMUNICATIONS

A Division of Pierce Manufacturing Inc.

San Ramon Valley  
Fire Department  
C-45 X-4 - M2-112

|       |        |              |        |
|-------|--------|--------------|--------|
| DRAWN | MRS    | DATE         | 1/6/22 |
| SHEET | 1 OF 6 | NOT TO SCALE |        |

|      |          |     |
|------|----------|-----|
| SIZE | DWG NO.  | REV |
| B    | P2022-36 | A   |

THIS DRAWING IS THE PROPERTY OF PIERCE MANUFACTURING. IT IS CONFIDENTIAL AND ALL RIGHTS ARE RESERVED. IT SHALL NOT BE REPRODUCED, COPIED, LENT, OR USED FOR ANY PURPOSE OTHER THAN THAT FOR WHICH IT IS SPECIFICALLY FURNISHED.

BID # XXXXX  
 REP: Rich Myers - Golden State Fire Apparatus  
 DEALER: Andy Callaway - Frontline Communications

PRELIMINARY USE ONLY  
 THIS DRAWING IS FOR REPRESENTATION ONLY. DETAILED ENGINEERING DRAWINGS WILL BE CREATED FOR MANUFACTURING. CHANGES MAY BE REQUIRED TO ACCOMMODATE MANUFACTURING REQUIREMENTS AND CUSTOMER SPECIFICATIONS.

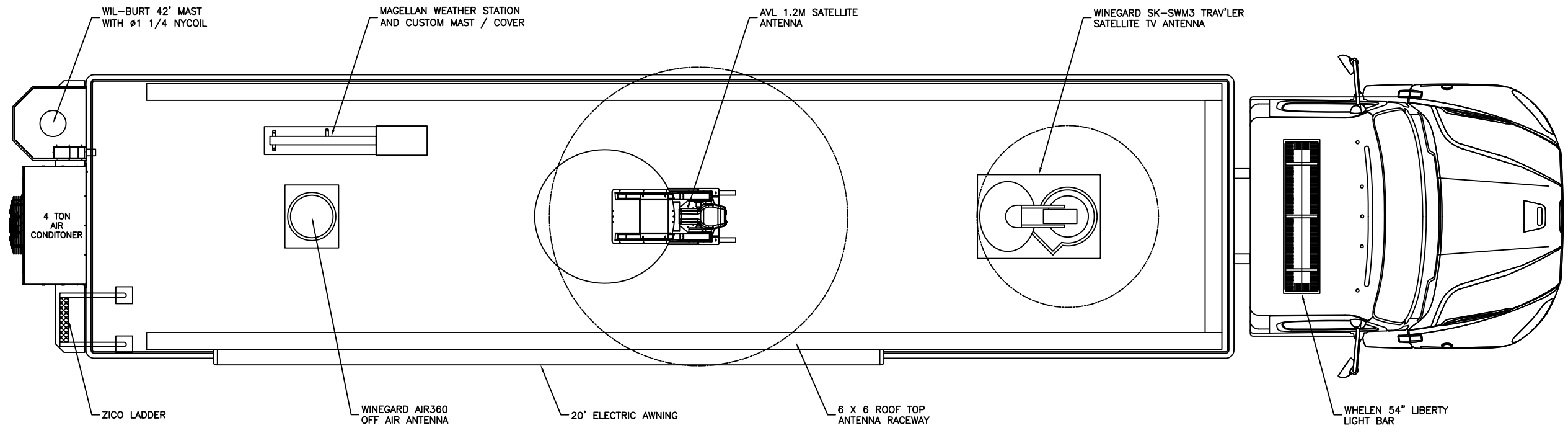

**FRONTLINE**  
COMMUNICATIONS  
A Division of Pierce Manufacturing Inc.

San Ramon Valley  
Fire Department  
C-45 X-4 - M2-112

THIS DRAWING IS THE PROPERTY OF PIERCE MANUFACTURING. IT IS CONFIDENTIAL AND ALL RIGHTS ARE RESERVED. IT SHALL NOT BE REPRODUCED, COPIED, LENT, OR USED FOR ANY PURPOSE OTHER THAN THAT FOR WHICH IT IS SPECIFICALLY FURNISHED.

BID # XXXXX  
REP: Rich Myers - Golden State Fire Apparatus  
DEALER: Andy Callaway - Frontline Communications

PRELIMINARY USE ONLY  
THIS DRAWING IS FOR REPRESENTATION ONLY. DETAILED ENGINEERING DRAWINGS WILL BE CREATED FOR MANUFACTURING. CHANGES MAY BE REQUIRED TO ACCOMMODATE MANUFACTURING REQUIREMENTS AND CUSTOMER SPECIFICATIONS.

|       |        |              |        |
|-------|--------|--------------|--------|
| DRAWN | MRS    | DATE         | 1/6/22 |
| SHEET | 1 OF 6 | NOT TO SCALE |        |

|      |          |     |
|------|----------|-----|
| SIZE | DWG NO.  | REV |
| B    | P2022-36 | A   |

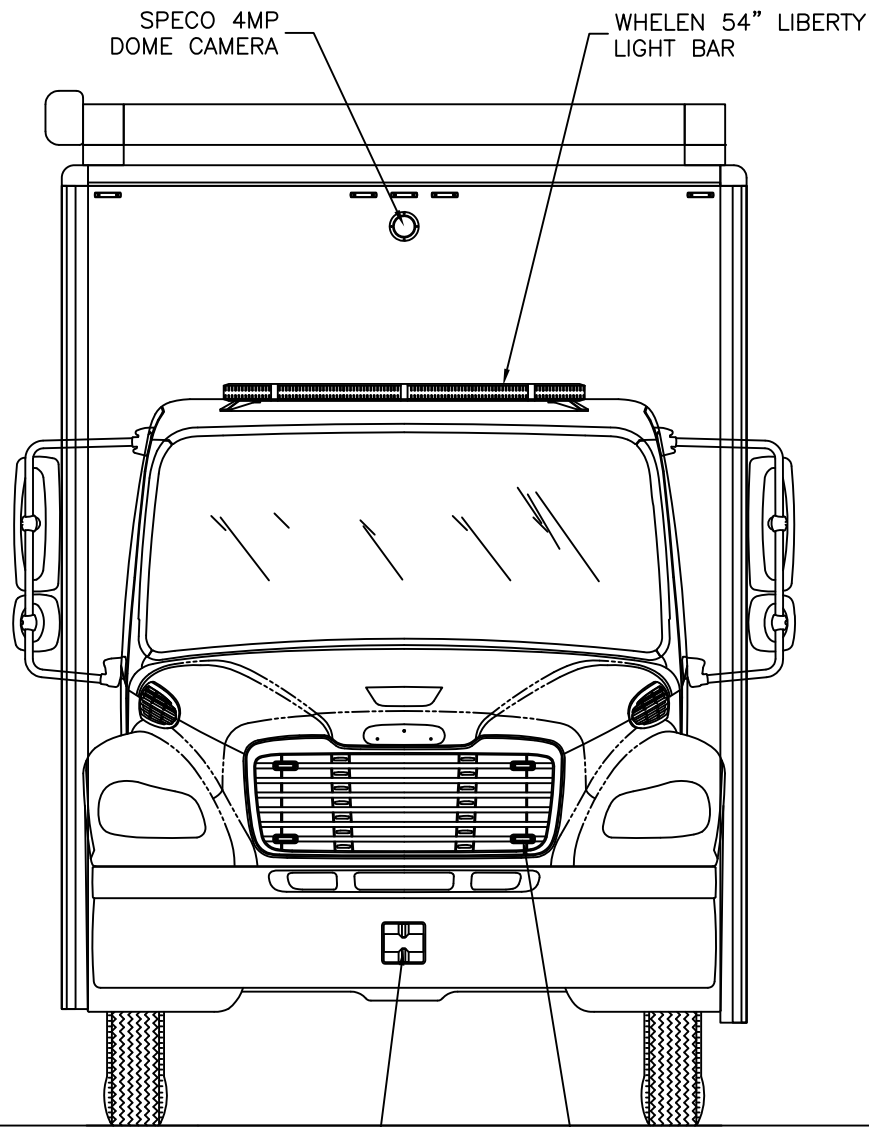

WHELEN SA315P SPEAKER  
MOUNTED BEHIND FRONT BUMPER

WHELEN TIR3  
EMERGENCY  
LIGHT (X4)

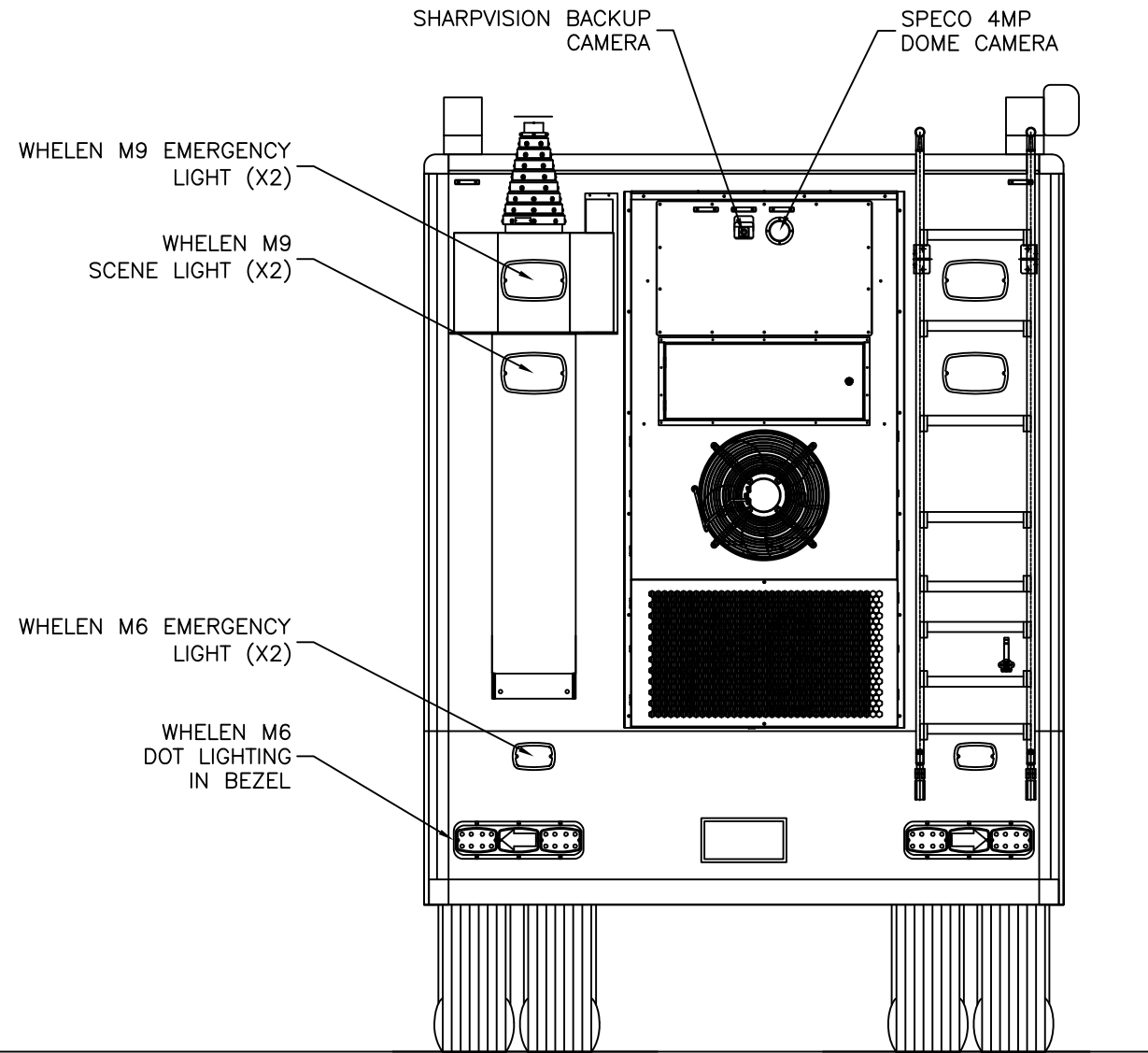

**FRONTLINE**  
COMMUNICATIONS

A Division of Pierce Manufacturing Inc.

San Ramon Valley  
Fire Department  
C-45 X-4 - M2-112

DRAWN

MRS

DATE

1/6/22

SIZE

B

DWG NO.

P2022-36

REV

A

SHEET

1 OF 6

NOT TO SCALE

BID # XXXXX

REP: Rich Myers - Golden State Fire Apparatus

DEALER: Andy Callaway - Frontline Communications

PRELIMINARY USE ONLY

THIS DRAWING IS FOR REPRESENTATION ONLY. DETAILED  
ENGINEERING DRAWINGS WILL BE CREATED FOR  
MANUFACTURING. CHANGES MAY BE REQUIRED TO  
ACCOMMODATE MANUFACTURING REQUIREMENTS AND  
CUSTOMER SPECIFICATIONS.

THIS DRAWING IS THE PROPERTY OF PIERCE  
MANUFACTURING. IT IS CONFIDENTIAL AND ALL RIGHTS ARE  
RESERVED. IT SHALL NOT BE REPRODUCED, COPIED, LENT,  
OR USED FOR ANY PURPOSE OTHER THAN THAT FOR WHICH  
IT IS SPECIFICALLY FURNISHED.

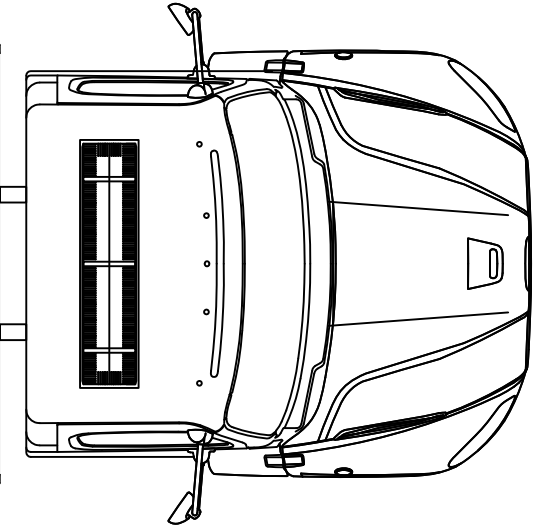
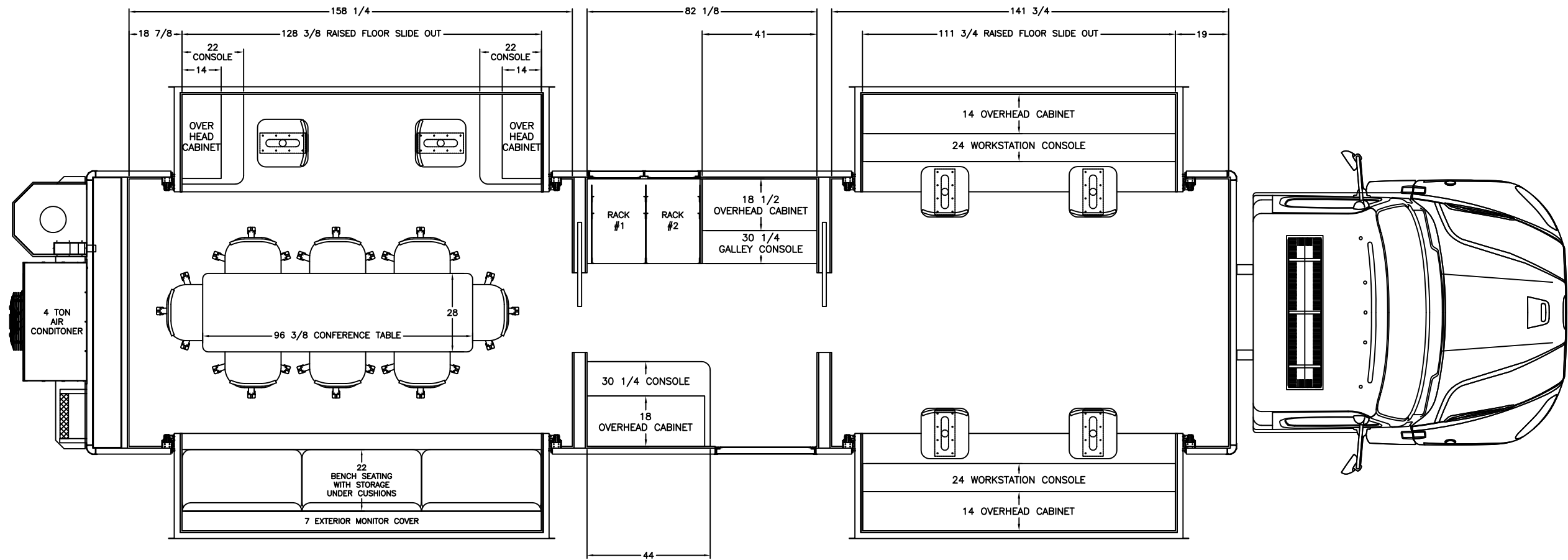

**FRONTLINE**  
COMMUNICATIONS  
A Division of Pierce Manufacturing Inc.

San Ramon Valley  
Fire Department  
C-45 X-4 - M2-112

THIS DRAWING IS THE PROPERTY OF PIERCE MANUFACTURING. IT IS CONFIDENTIAL AND ALL RIGHTS ARE RESERVED. IT SHALL NOT BE REPRODUCED, COPIED, LENT, OR USED FOR ANY PURPOSE OTHER THAN THAT FOR WHICH IT IS SPECIFICALLY FURNISHED.

BID # XXXXX  
REP: Rich Myers - Golden State Fire Apparatus  
DEALER: Andy Callaway - Frontline Communications

PRELIMINARY USE ONLY  
THIS DRAWING IS FOR REPRESENTATION ONLY. DETAILED ENGINEERING DRAWINGS WILL BE CREATED FOR MANUFACTURING. CHANGES MAY BE REQUIRED TO ACCOMMODATE MANUFACTURING REQUIREMENTS AND CUSTOMER SPECIFICATIONS.

DRAWN MRS DATE 1/6/22  
SHEET 1 OF 6 NOT TO SCALE

SIZE B DWG NO. P2022-36 REV A

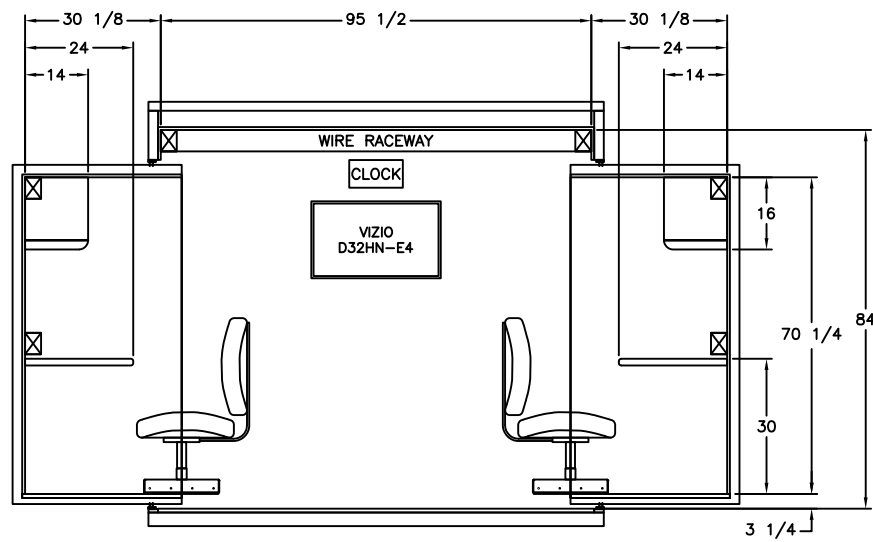

FRONT WALL INTERIOR LAYOUT

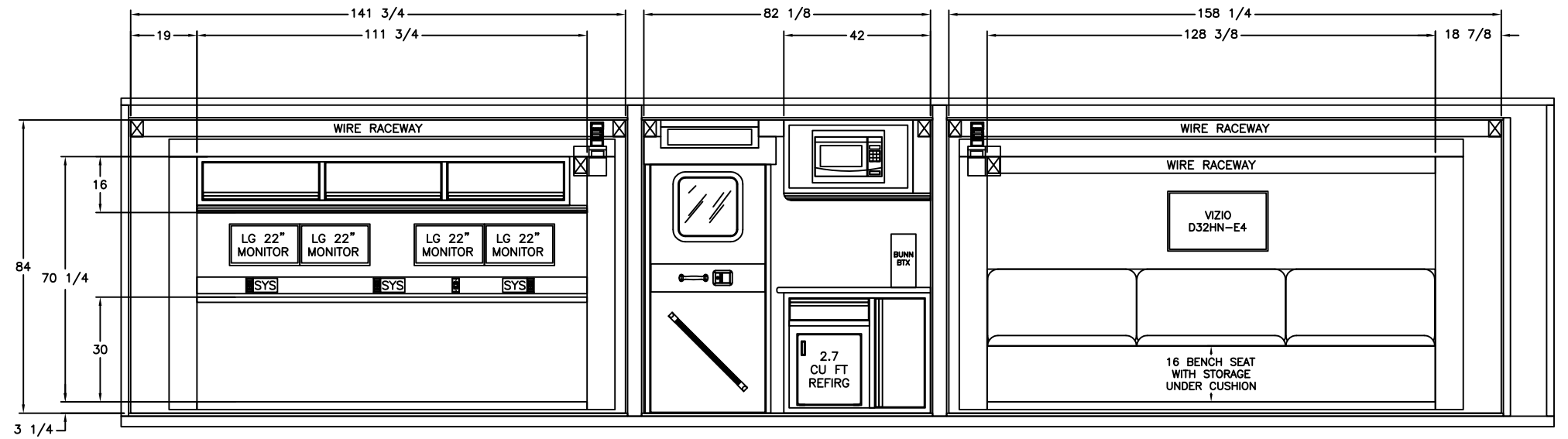

PASSENGER SIDE INTERIOR LAYOUT

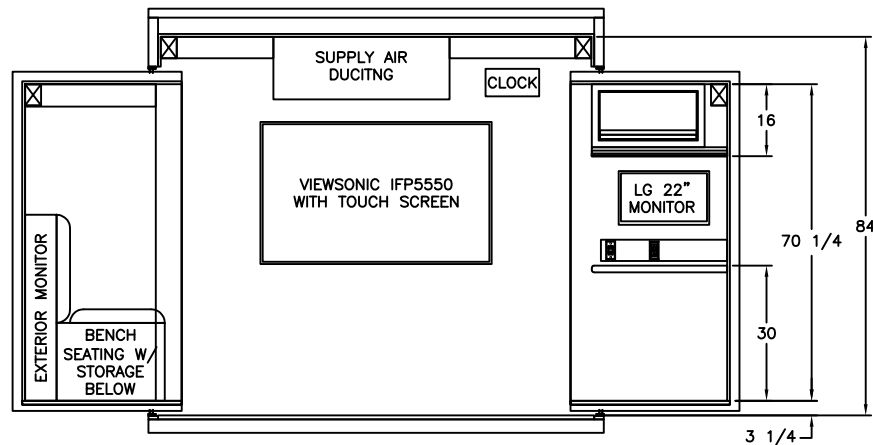

REAR WALL INTERIOR LAYOUT

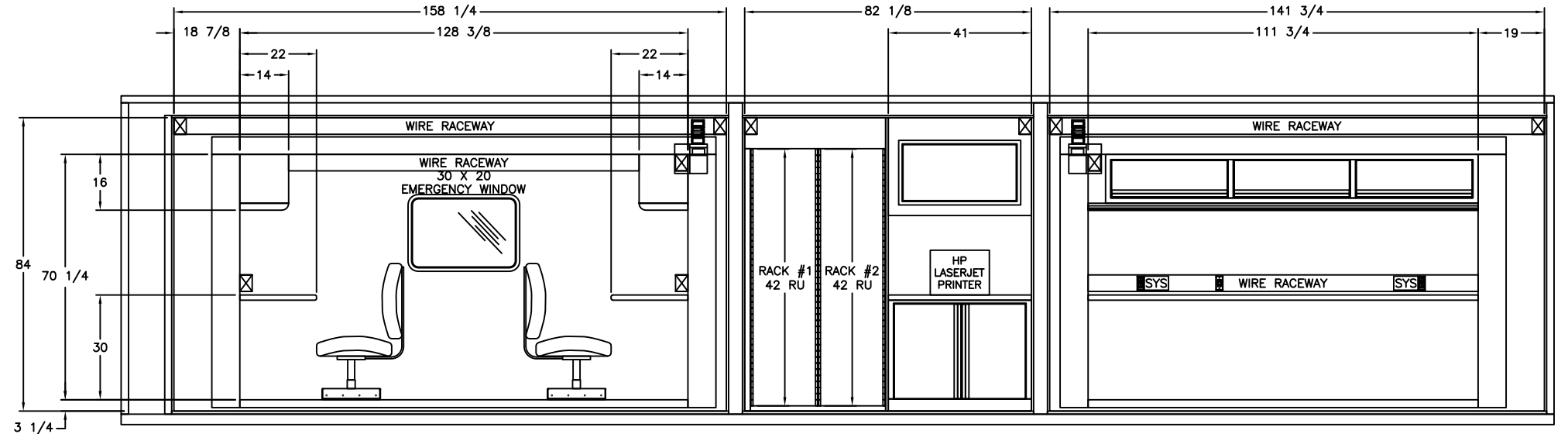

DRIVER SIDE INTERIOR LAYOUT

**FRONTLINE**  
COMMUNICATIONS

A Division of Pierce Manufacturing Inc.

San Ramon Valley  
Fire Department  
C-45 X-4 - M2-112

THIS DRAWING IS THE PROPERTY OF PIERCE MANUFACTURING. IT IS CONFIDENTIAL AND ALL RIGHTS ARE RESERVED. IT SHALL NOT BE REPRODUCED, COPIED, LENT, OR USED FOR ANY PURPOSE OTHER THAN THAT FOR WHICH IT IS SPECIFICALLY FURNISHED.

BID # XXXXX  
REP: Rich Myers - Golden State Fire Apparatus  
DEALER: Andy Callaway - Frontline Communications

PRELIMINARY USE ONLY  
THIS DRAWING IS FOR REPRESENTATION ONLY. DETAILED ENGINEERING DRAWINGS WILL BE CREATED FOR MANUFACTURING. CHANGES MAY BE REQUIRED TO ACCOMMODATE MANUFACTURING REQUIREMENTS AND CUSTOMER SPECIFICATIONS.

DRAWN MRS DATE 1/6/22  
SHEET 1 OF 6 NOT TO SCALE

SIZE DWG NO. REV  
B P2022-36 A